

FIGURE #1 FRAME COMPONENTS

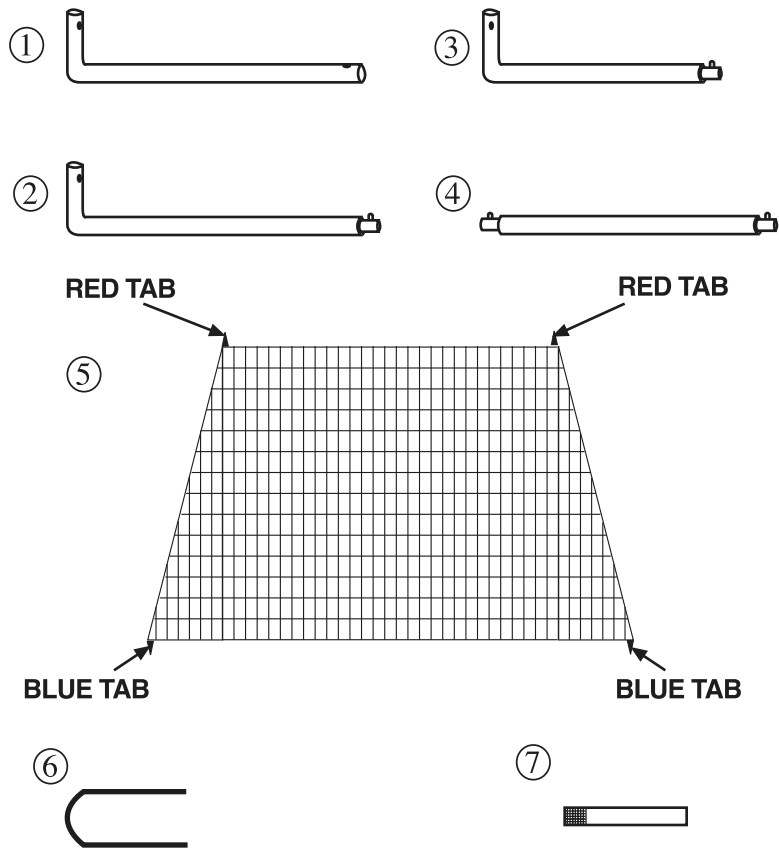
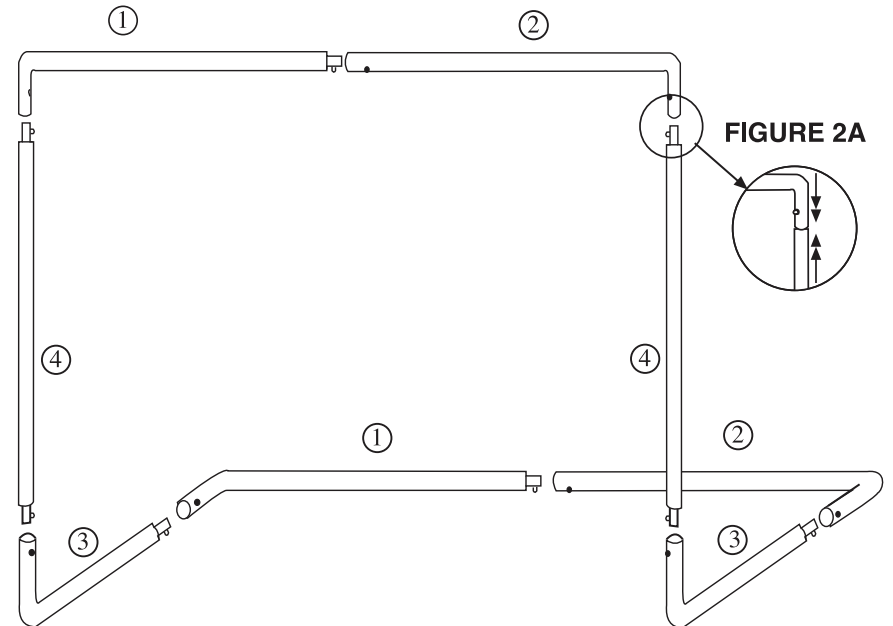

Figure #2 FRAME ASSEMBLY

Assemble all lengths of tubing as shown in Figure 1. Be sure that the piece is inserted completely. The ends of each tube insert tightly and are secured when the press button of the tapered end pops through the adjoining perforated tube. (Refer to figure 2a.)



PART	QTY	DESCRIPTION	
①	2	L Shape Tube	8 1/4" x 37 1/4" (press button on tapered end)
②	2	L Shape Tube	8 1/4" x 37 1/4" (perforated end)
③	2	L Shape Tube	8 1/4" x 30" (press button on tapered end)
④	2	Straight Tube	36" (press button on both tapered ends)
⑤	1	Mesh Net	168" x 60" x 4" (4" x 4")
⑥	4	U Shape Ground Stake	8"
⑦	30	Self-Stick Closure Strips	8" x 3/4"

Step Assembly Instructions

1. Assemble the first set of tubes parts ① & ② . This will create the back base.
2. Insert tapered tubes part ③ to the back base.
3. Insert tapered tubes part ④ as shown into the upward reaching section of tubes part ③.
4. After assembling the second set of tubes parts ① & ②, place these on the tapered sections of tubes part ④ to complete the frame assembly.